

COMPLÉMENT À LA FICHE D'HOMOLOGATION
 SUPPLEMENT TO THE HOMOLOGATION FORM

Homologation N°

16/SA/18
 02/01/SUP







COMMISSION INTERNATIONALE
 DE KARTING – FIA



SILENCIEUX D'ASPIRATION / INTAKE SILENCER

Constructeur	<i>Manufacturer</i>	Righetti Ridolfi S.p.A.
Marque	<i>Make</i>	Righetti Ridolfi
Modèle	<i>Model</i>	NOX 23
Catégories	<i>Categories</i>	KF4, KF3, KF2 & KF1
Nombre de pages	<i>Number of pages</i>	2

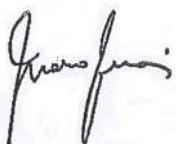
	
PHOTO DE L'AVANT PHOTO OF THE FRONT	PHOTO DE CÔTÉ PHOTO OF THE SIDE

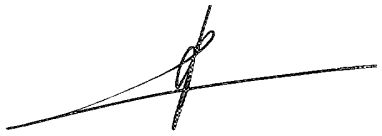
Signature et tampon de l'ASN Signature and stamp of the ASN	Signature et tampon de la CIK-FIA Signature and stamp of the CIK-FIA
 	 

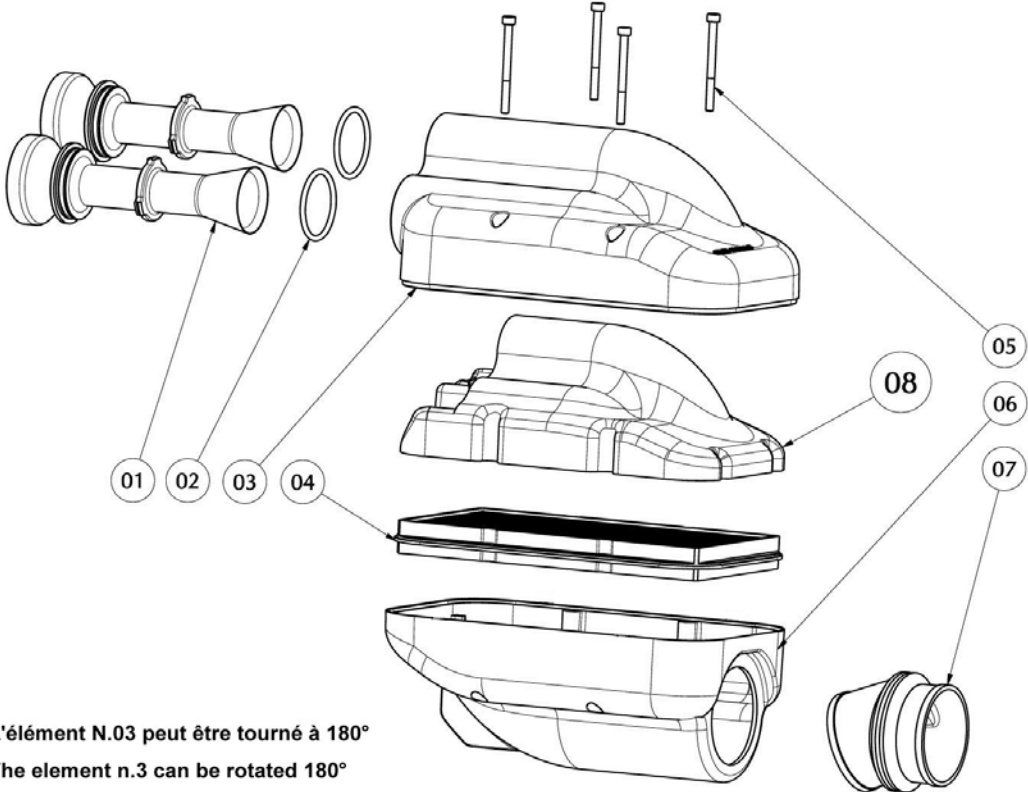
A2	Dessin technique explosé	A2	Exploded technical drawing
 <p data-bbox="252 1182 638 1243">L'élément N.03 peut être tourné à 180° The element n.3 can be rotated 180°</p>			
<p data-bbox="76 1317 1509 1435">Le dessin technique explosé doit montrer : <u>Éléments du silencieux, éléments acoustiques absorbants, éléments filtrants, tubes d'aspiration et manchon de fixation au carburateur.</u> The exploded technical drawing must show the following: <u>parts of the silencer, noise-absorbing parts, filtering parts, suction tubes and carburettor clamping sleeve.</u></p>			

N°	DÉSIGNATION	DESIGNATION	Référence catalogue Catalogue reference number
01	Tubes d'Aspiration D.23mm	Suction Tubes D.23mm	ZZKE012
02	O-Ring	O-Ring	KE067
03	Corps filtre supérieur	Upper body filter	ZZKE006
04	Filtre	Filter	ZZKE011
05	Vis M5	Screw M5	KVP05050S
06	Corps filtre côté moteur	Engine side body filter	ZZKE007
07	Raccord en caoutchouc	Rubber Connector	K070
08	Éléments acoustiques absorbants	Noise-absorbing parts	KE062

COMPLÉMENT À LA FICHE D'HOMOLOGATION
 SUPPLEMENT TO THE HOMOLOGATION FORM

Homologation N°

19/SA/18
 02/01/SUP







COMMISSION INTERNATIONALE
 DE KARTING – FIA

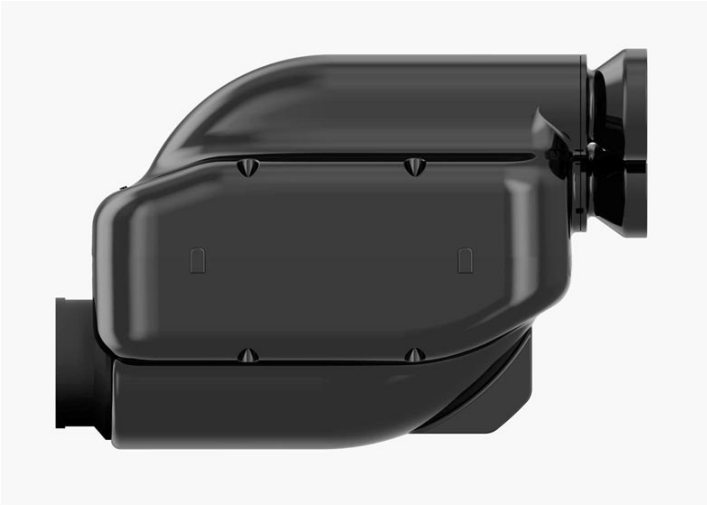

SILENCIEUX D'ASPIRATION / INTAKE SILENCER

Constructeur	<i>Manufacturer</i>	Righetti Ridolfi S.p.A.
Marque	<i>Make</i>	Righetti Ridolfi
Modèle	<i>Model</i>	NOX D.30
Catégories	<i>Categories</i>	KZ
Nombre de pages	<i>Number of pages</i>	2

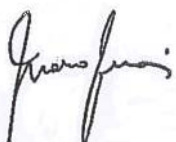
	
PHOTO DE L'AVANT PHOTO OF THE FRONT	PHOTO DE CÔTÉ PHOTO OF THE SIDE

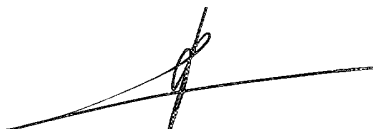
Signature et tampon de l'ASN Signature and stamp of the ASN	Signature et tampon de la CIK-FIA Signature and stamp of the CIK-FIA
 	 

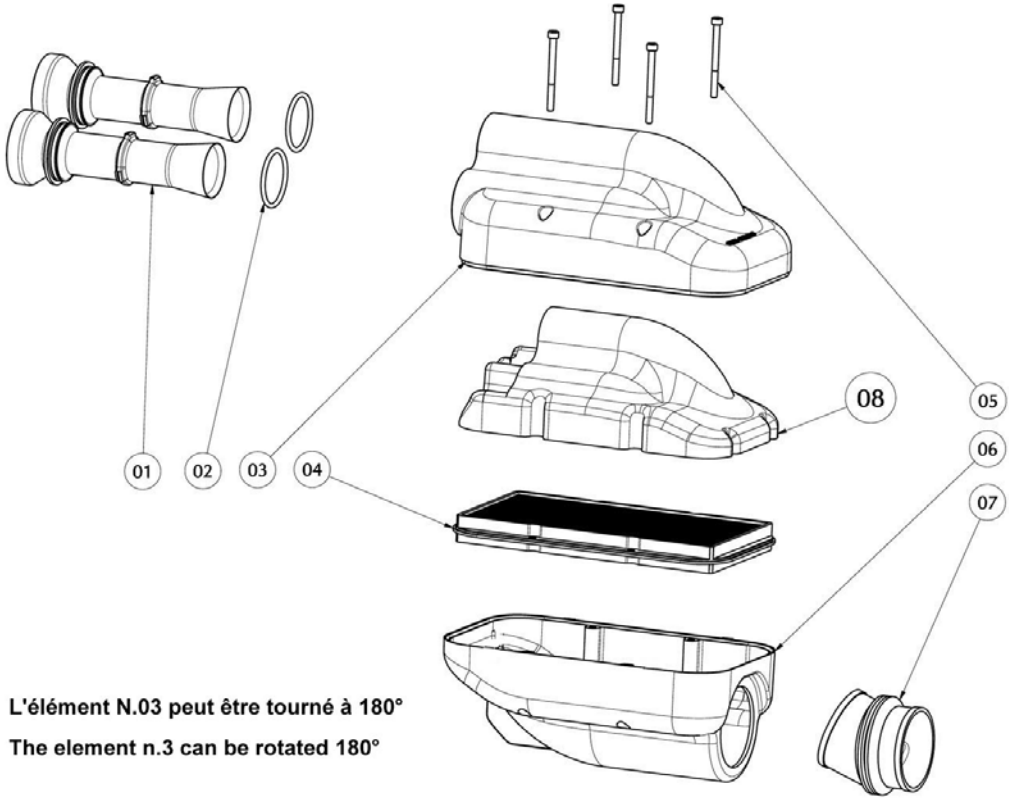
A2	Dessin technique explosé	A2	Exploded technical drawing
 <p data-bbox="280 1155 679 1218">L'élément N.03 peut être tourné à 180° The element n.3 can be rotated 180°</p>			
<p data-bbox="76 1350 1509 1467">Le dessin technique explosé doit montrer : <u>Éléments du silencieux, éléments acoustiques absorbants, éléments filtrants, tubes d'aspiration et manchon de fixation au carburateur.</u> The exploded technical drawing must show the following: <u>parts of the silencer, noise-absorbing parts, filtering parts, suction tubes and carburettor clamping sleeve.</u></p>			

N°	DÉSIGNATION	DESIGNATION	Référence catalogue Catalogue reference number
01	Tubes d'Aspiration D.30mm	Suction Tubes D.30mm	ZZKE013
02	O-Ring	O-Ring	KE067
03	Corps filtre supérieur	Upper body filter	ZZKE006
04	Filtre	Filter	ZZKE011
05	Vis M5	Screw M5	KVP05050S
06	Corps filtre côté moteur	Engine side body filter	ZZKE007
07	Raccord en caoutchouc	Rubber Connector	K070
08	Éléments acoustiques absorbants	Noise-absorbing parts	KE062